

Packing List			
Mark	Model	Description	Qty
		Screws	10
Bl	B35	Sink Base w/ Doors Right Sink	1
Cl	model	Work Surface w/ Right Sink	1
Pl		Door/Drawer Pull	4
Ul	U31	Upper Dispense Cabinet	1

Backers	
Description	Length
2x6 Backer	2' - 4 3/16"
2x6 Backer	2' - 4 3/16"
2x6 Backer	2' - 4 3/16"
2x6 Backer	4' - 7 5/32"

Utilities		
Mark	Description	Qty
H	Hot Water Supply	1
C	Cold Water Supply	1
D	Sanitary DWV	1

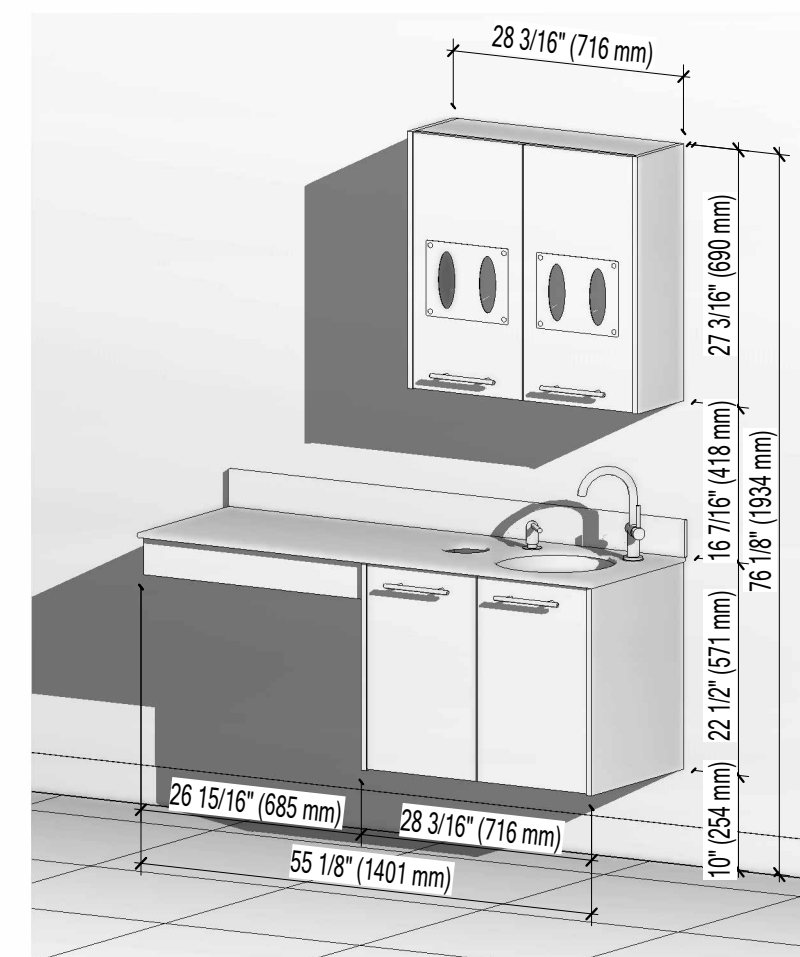
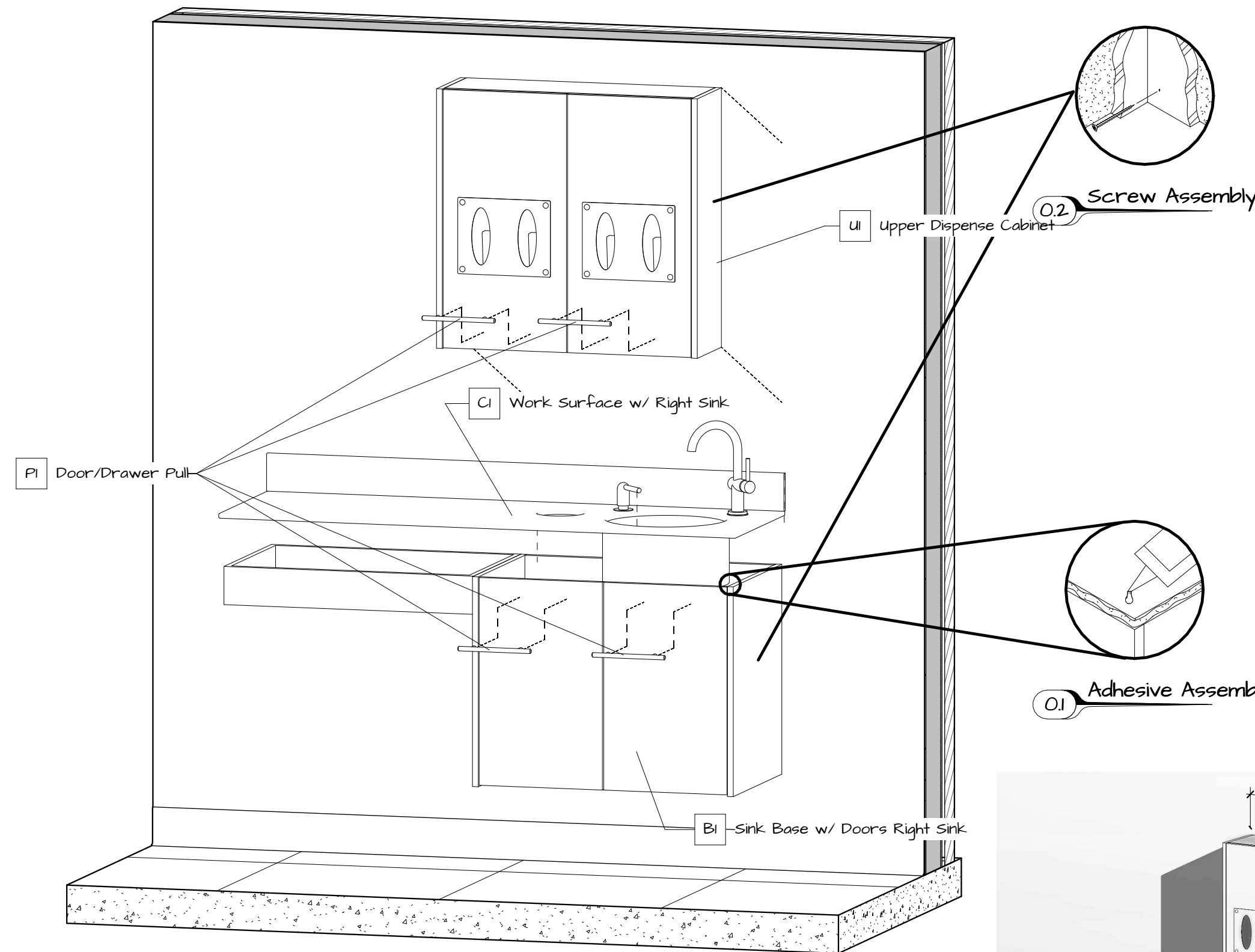
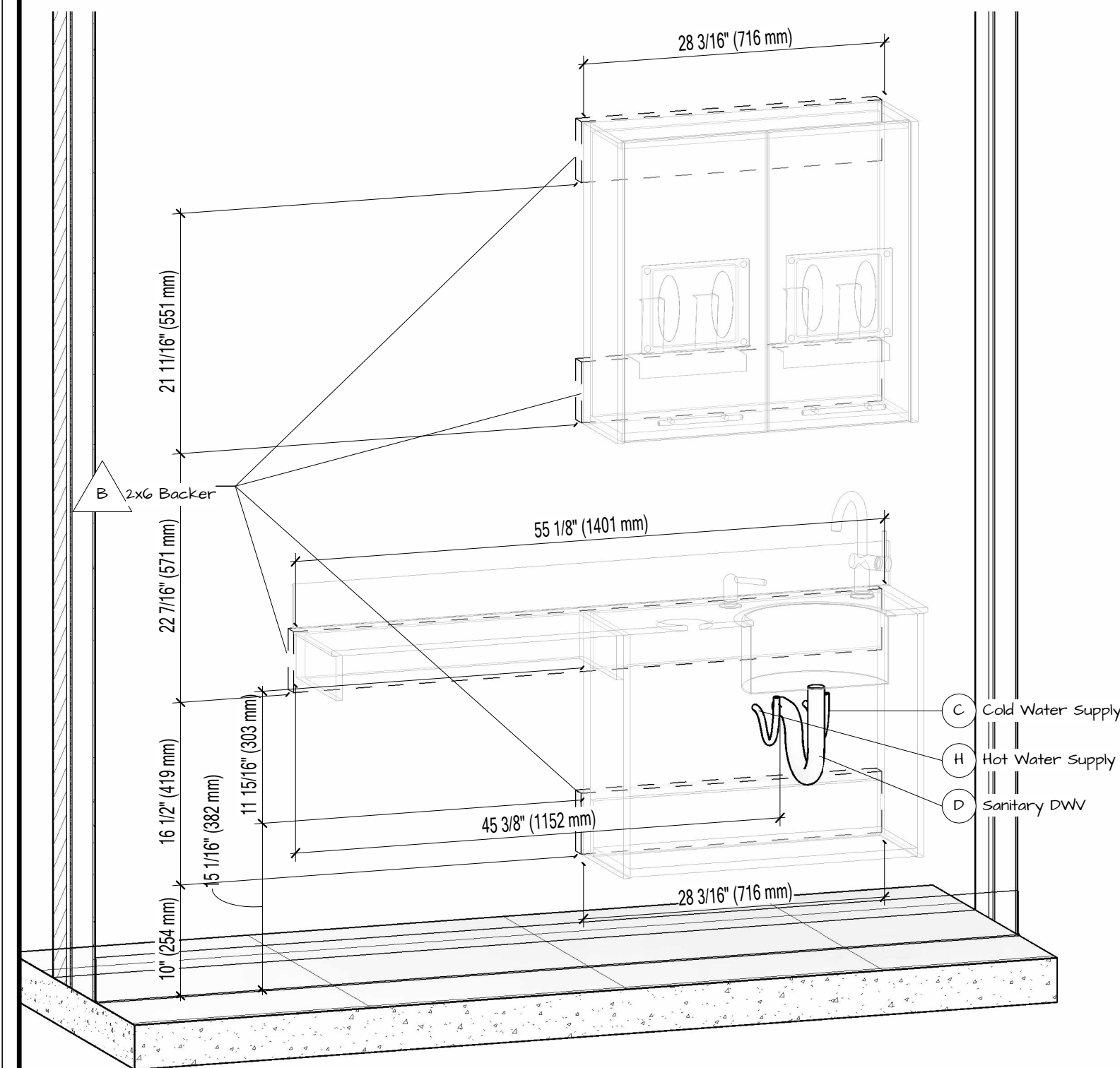

1 Utilities Location

2 Front Install

3 Final Installation View



NOVA Solutions Inc.
217-342-7070
sales@novasolutionsinc.com

Installation Drawing

Title ALSTC B35-H00-U31
Date 4/26/2024
Drawn by Justin Martin

I-1