

1 Utilities Location

Backers	
Description	Length
2x6 Backer	2' - 4 7/32"
2x6 Backer	2' - 4 7/32"
	4' - 8 13/32"

Packing List		
Mark	Description	Qty
	#12 3" Wood Screws	4
	Anchor Bolts	8
	Tube of Caulk	1
B	Side Console Base	1
C	Work Surface w/ Sink	1
P1	Door/Drawer Pull	12
U	Upper Dispense Cabinet	1

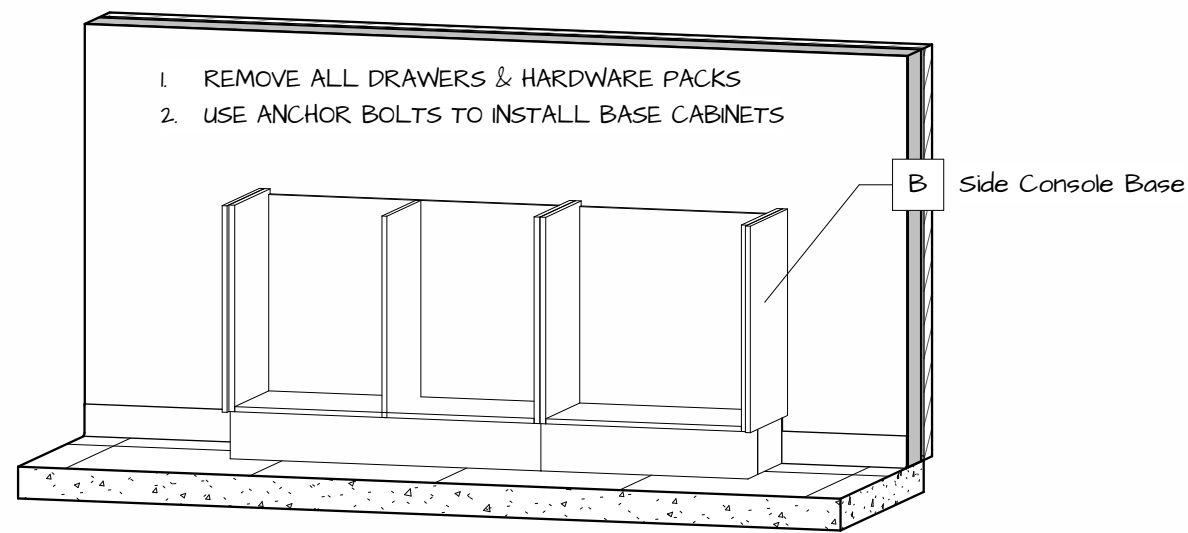

2.1 Install Base Cabinets

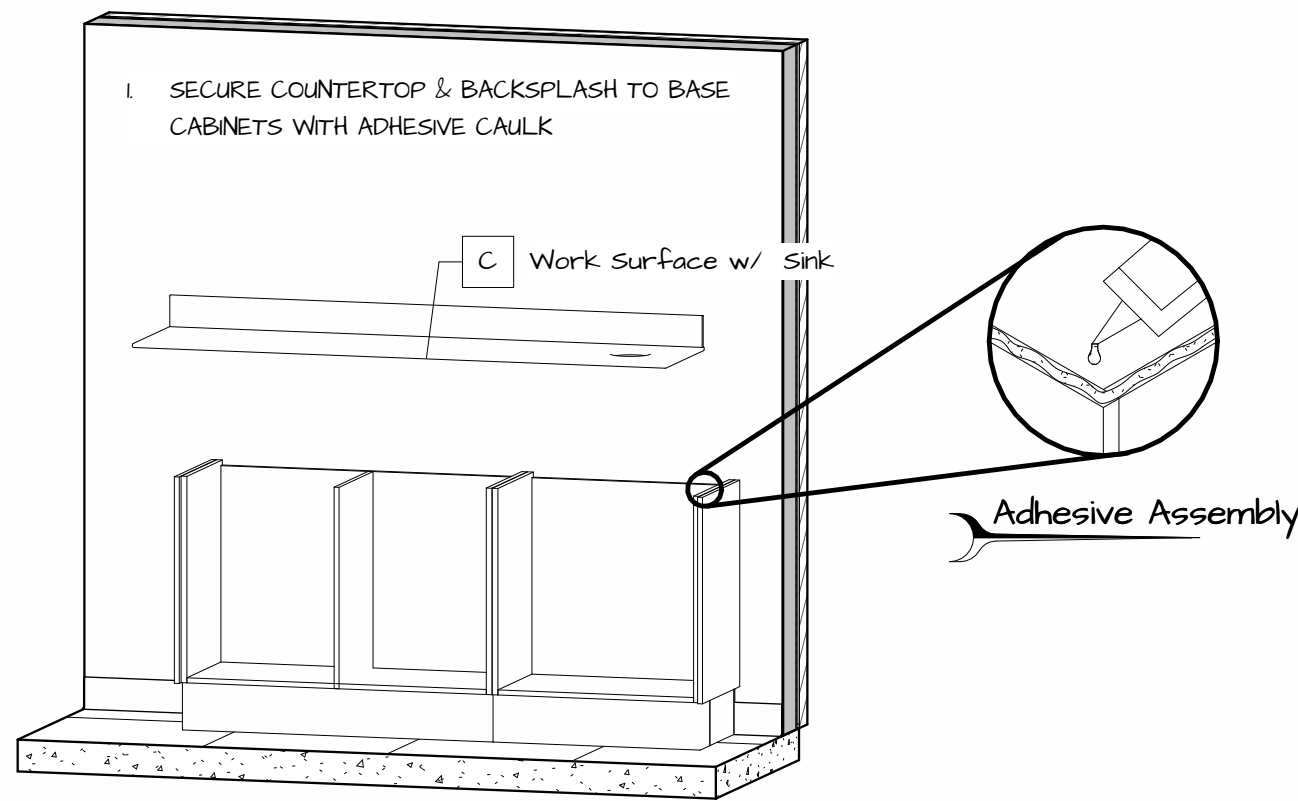

2.2 Install CounterTop

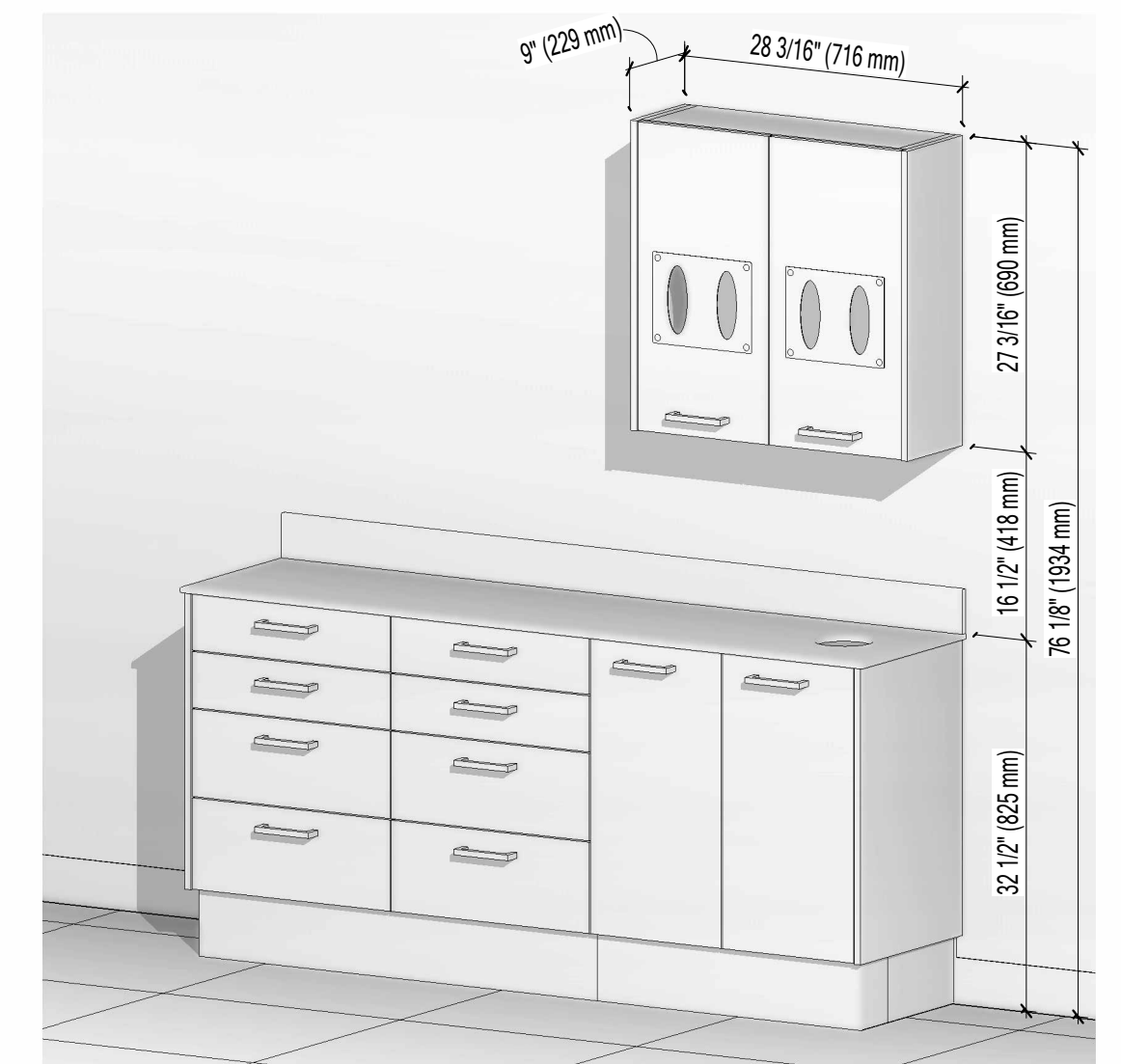

3 Final Installation View

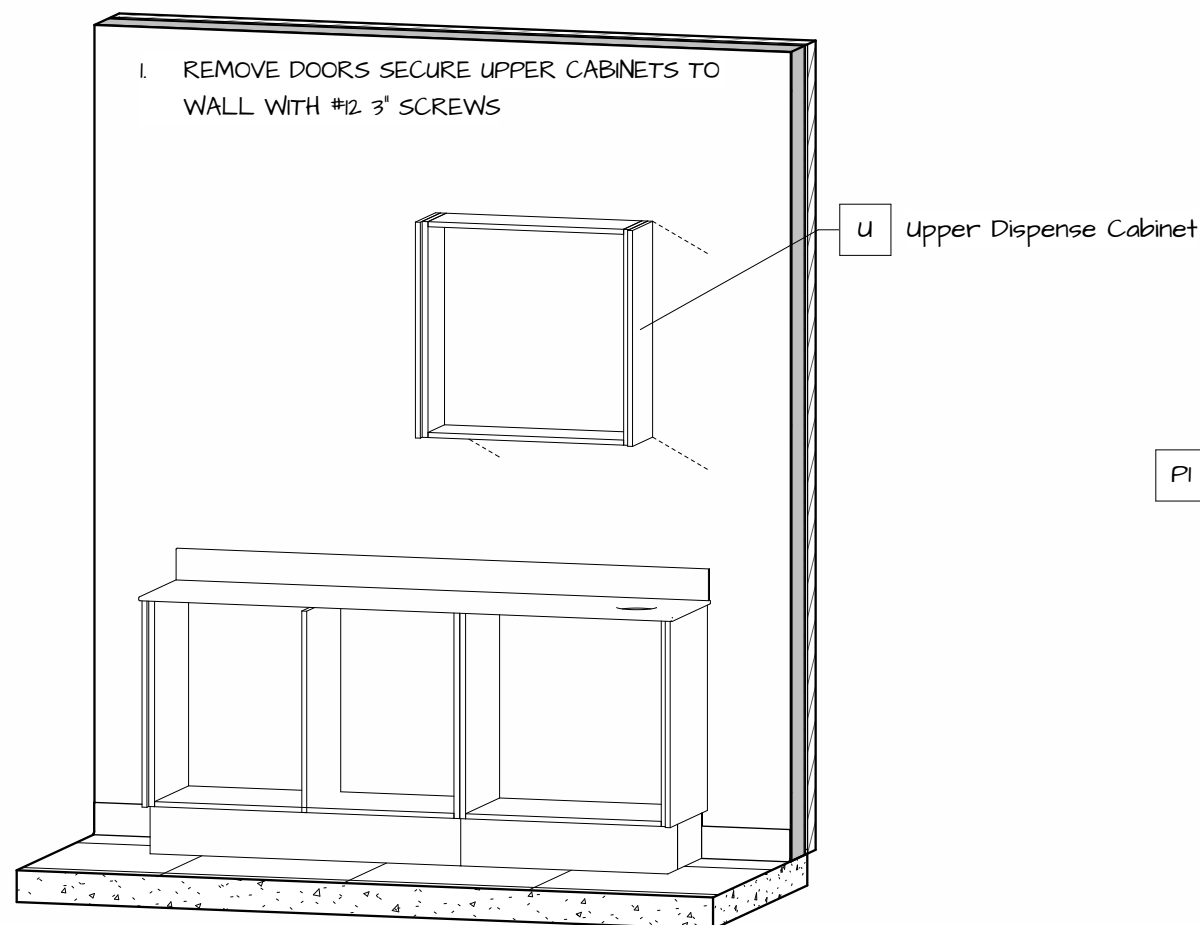

2.3 Install Upper Cabinets

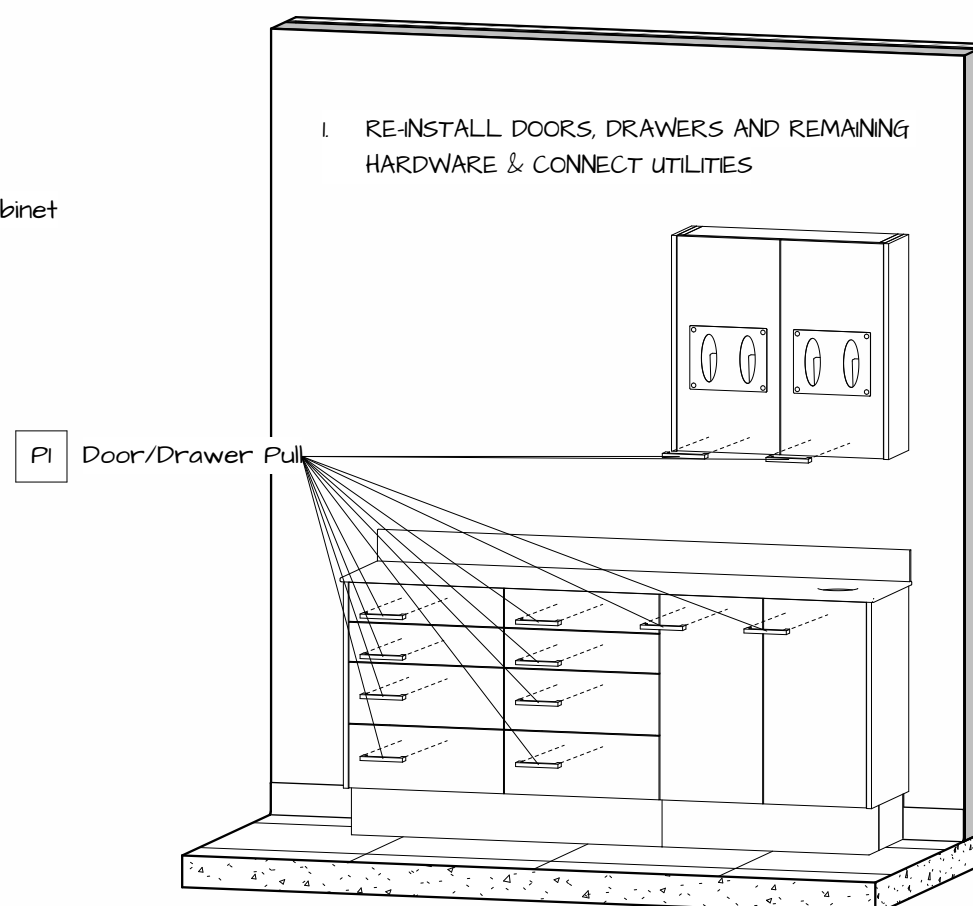

2.4 Install Hardware

**anthos**  
NOVA Solutions Inc.  
217-342-7070  
sales@novasolutionsinc.com

Installation Drawing		Prepared For: Nova Solutions Inc.
<b>LINEA</b>		
Project	REAR TREATMENT CENTER	<b>I-1</b>
Item #	ALSTC 03N-000-U31	
Drawn by:	Justin Martin	09/28/24
		Rev. 1